

Motor Operator



Motor operator is a device that can be used to operate the breaker remotely. Motor operators can also be operated manually. The motor drives a mechanism which switches TS toggle handle to “ON” and “OFF/RESET” positions.

- The manual actuator handle is located on the front of the cover.
- Manual or Automatic operation can be selected.
- Applicable to 2, 3 and 4-pole breakers.

The motor operator is an essential device for constructing a remotely operated automatic source-changeover system that ensure a continuous supply of electrical power to the following sectors:

- Commercial sector: Hospital, Tall building, Bank, Insurance companies, Shopping centres.
- Industry: Ships, Assembly lines at plant, Military sites, Port and Railway installation.

Part Number	Description	Actuation current (A)	Response Time		Consumption (W)	Mechanical Service Life (Operations)	No. of Operations per hour	Suitable MCCB
			Closing	Opening				
LS-MOP2-24	Motor Operator 24VAC	≤5 (DC24V)	350	230	14	25000	120	TS100/160/250
LS-MOP2-240	Motor Operator 100-240VAC/100-200VDC		350	230	14	25000	120	TS100/160/250
LS-MOP3-24	Motor Operator 24VAC		500	350	35	20000	60	TS400/630
LS-MOP3-110	Motor Operator 100-110VAC		500	350	35	20000	60	TS400/630
LS-MOP3-230	Motor Operator 230VAC/220VDC		500	350	35	20000	60	TS400/630
LS-MOP4-24	Motor Operator 24VAC		≤2A (AC)	700	420	35	10000	20
LS-MOP4-110	Motor Operator 100-110VAC	700		420	35	10000	20	TS800
LS-MOP4-230	Motor Operator 230VAC/220VDC	700		420	35	10000	20	TS800

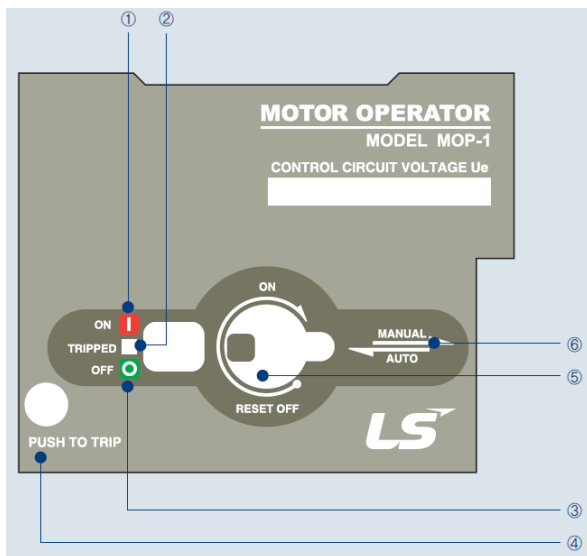

1. On position indication (Red)
2. Trip position indication (White)
3. Off position indication (Green)
4. Button for push to trip (available for only for TD160AF and TS630AF)
5. On/Off/Reset selection lever
6. Manual/Auto selection lever

Wiring Connections

Standard Connection

The Circuit breaker can be operated remotely or manually.

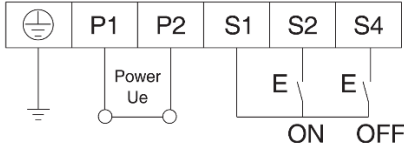

Connection with an alarm switch (AL)

Below diagram illustrates the wiring connections needed for alarm switch without shunt or undervoltage trip. After a trip caused due to an electrical fault, a Manual reset is mandatory (after clearing the fault).

Connection with a Fault alarm switch (FAL)

Below diagram illustrates the wiring connections needed for fault alarm switch without shunt or undervoltage trip.

After a trip caused due to an electrical fault, a Manual reset is mandatory (after clearing the fault).

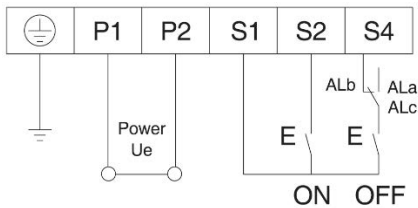

**** Both AL and FAL Auxiliaries uses the same circuit diagram. AL=FAL**

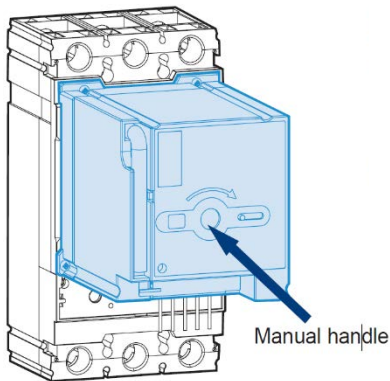

Manual Operation

1. Insert the manual handle into the slot of Motor Operator surface and rotate it clockwise.
2. It must be rotated just 180° clockwise for safe operation of micro switch in the motor operator.
3. Return the manual handle after the manual operation
4. Turn the slide switch back to the position of AUTO.

Automatic operation

1. Set the slide switch to AUTO, then internal power is closed automatically.
2. Operating frequency should be less than these below regulated values. TD160N/H/L, TS250N/H/L:180 operations per hour
3. Use the ON/OFF switch in the range of regulated values.
4. It may interfere near communication equipment's because of internal switching power supply. It is recommended that a noise filter be installed to power supply.
5. Please do not input ON/OFF signals at the same time during the automatic operation.
6. If the circuit breaker has a UVT attached inside, charge the UVT on the rated voltage before performing the MOTOR OPERATOR.

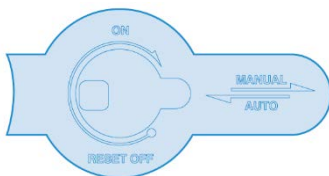

[TD100, 160, TS100, 160, 250]

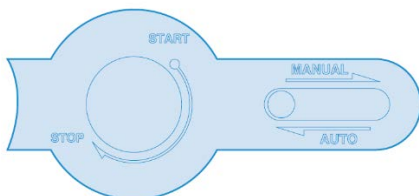

[TS400, 630, 800]

Catalogue number: **LS-MOP**□-□□

Motor Operator



Dimensions for MOP2

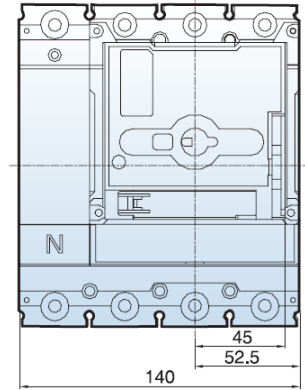
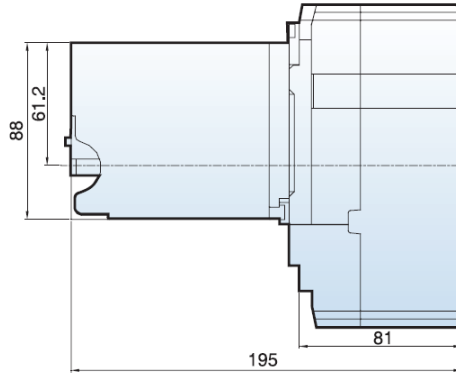
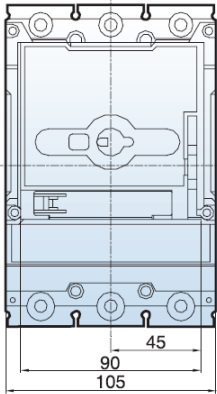

Dimensions for MOP3

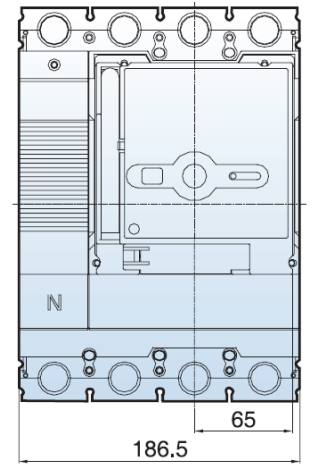
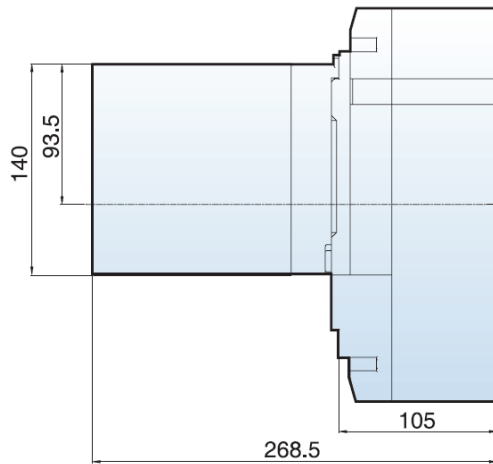
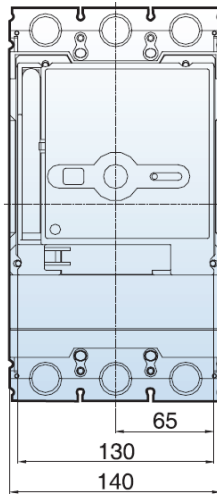

Dimensions for MOP4

